



# Fabricated Products (UK) Ltd

The Ickles, Unit 2, Sheffield Road, Rotherham, S60 1BN

Tel. 01709 720 842 - Fax. 01709 720 846

[www.fabricatedproducts.co.uk](http://www.fabricatedproducts.co.uk) Email: [info@fabricatedproducts.co.uk](mailto:info@fabricatedproducts.co.uk)

## MICROBUBBLE AIR SEPARATORS

# The CleanVent (CVA) Standard

Standard Unit for flow rates up to 1.5m/s. For high flow see our CVA-HF

An air & microbubble free water system

### Deaeration

The word Deaeration describes the removal of dissolved gases from liquids such as air from water. When water is heated or the pressure reduced gas microbubbles are released into the system. Microbubbles can be the cause of major problems such as pump failure, corrosion and energy loss.

### The Solution

The CleanVent removes air and microbubbles, Installed at the hottest point in the system the CleanVent will eliminate these microbubbles from heating and chilled water systems.

### Features

- \* Greatly reduced commissioning times after initial fill.
- \* Longer system life (through air and dirt elimination)
- \* Low-pressure drop
- \* Bi-directional flow
- \* Maximum Temperature. 110 °c. Higher temperature units available on request.
- \* Tested to 21 bar
- \* Standard carbon steel shell (stainless on request)
- \* Air collects in the air chamber before being automatically vented
- \* The fast bleed valve is used for releasing air when filling the system
- \* An internal stainless steel concentrator to aid removal of Air.
- \* Maximum flow rate 1.5m/sec. Higher flow rates upto 3m/sec require our Hi-Flow unit CVA-HF

### CleanVent Location

This unit (our model ref CVA) must be installed at the hottest part of the system (before the pumps). In a heating system this is the main flow from the boilers.  
The static head must not exceed 30 metres.

In a chilled water system the unit must be located in the return close to the chiller.  
Maximum static head must not exceed 15 metres.

N.B. if the static head is greater than these figures the efficiency of the CleanVent is reduced.

## Commissioning

The CleanVent requires no special commissioning. All units are fitted with a fast bleed valve, which should be used when initially filling the system. The same valve is used for draining off floating scum and also prevents the possibility of dirt clogging the air vent.

Most of the dissolved air will be removed in a few days. However this may vary from system to system. In large systems it may take several weeks.

## Flanges

All flanges are drilled to BS 4504 PN16 as standard. Plain ends and other flange rating are available on request.

The CleanVent unit is maintenance free.

\*\* Please note a limited amount of dirt may be collected in the Air Separator therefore periodically (every 3 to 6 months) please open the valve at the base of the unit and flush to drain.





# Fabricated Products (UK) Ltd

The Ickles, Unit 2, Sheffield Road, Rotherham, S60 1BN

Tel. 01709 720 842 - Fax. 01709 720 846

[www.fabricatedproducts.co.uk](http://www.fabricatedproducts.co.uk) Email: [info@fabricatedproducts.co.uk](mailto:info@fabricatedproducts.co.uk)

## Air & Microbubble Separator (de-aerator) - Model CVA

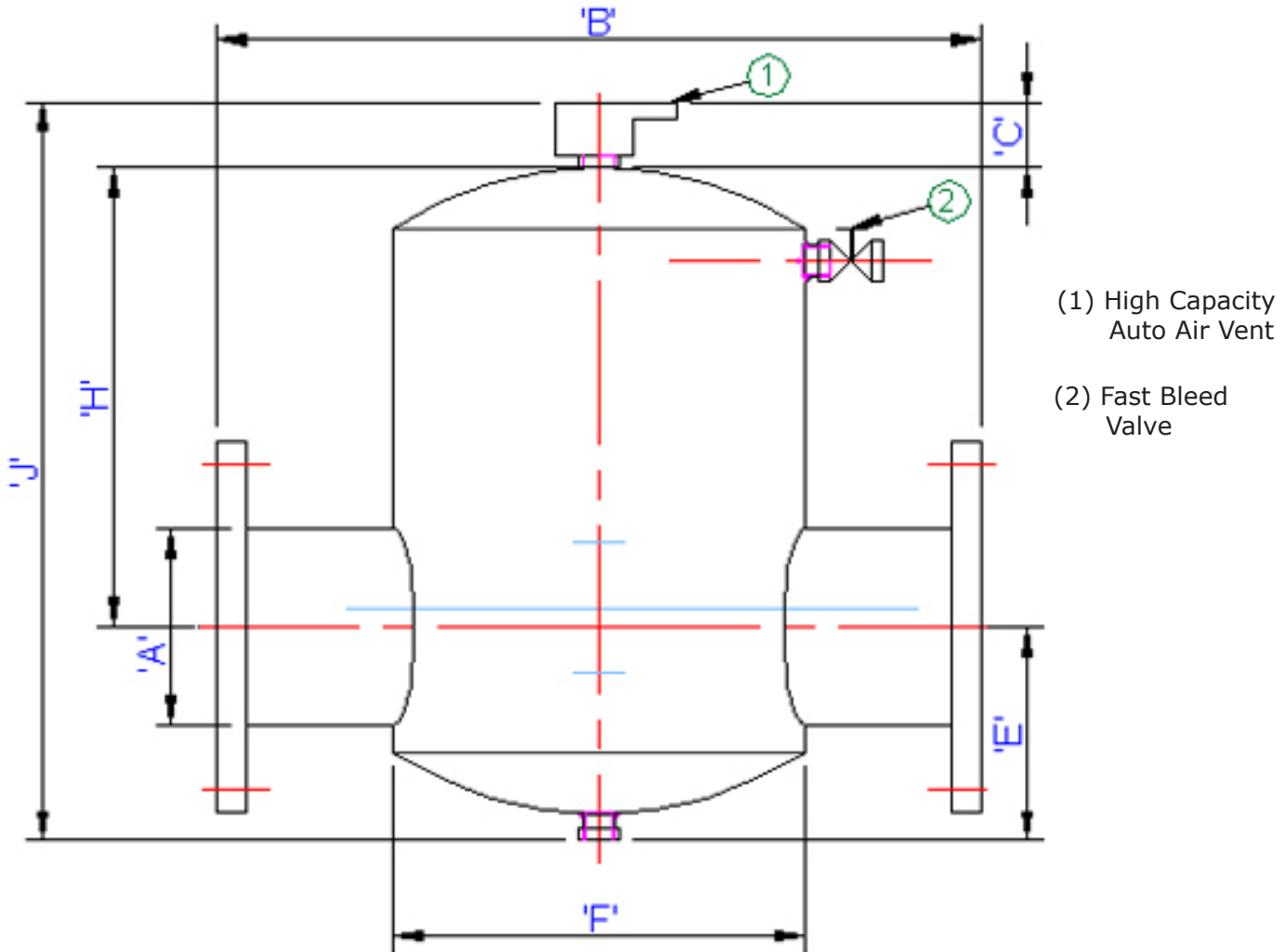

Product Code	DIMENSION'S							Test Press
	A	B	C	E	F	H	J	
CVA-50	50	350	120	120	170	200	440	21 Bar
CVA-65	65	350	120	120	170	200	440	21 Bar
CVA-80	80	460	120	150	220	305	575	21 Bar
CVA-100	100	460	120	150	220	305	575	21 Bar
CVA-125	125	630	120	220	325	420	760	21 Bar
CVA-150	150	630	120	220	325	420	760	21 Bar
CVA-200	200	810	120	260	410	420	800	21 Bar
CVA-250	250	880	120	320	510	640	1080	21 Bar
CVA-300	300	1100	120	360	610	900	1380	21 Bar
CVA-350	350	1100	120	410	770	900	1430	21 Bar
CVA-400	400	1250	120	430	770	1000	1550	21 Bar
CVA-450	450	1250	120	495	920	1000	1615	21 Bar

## Positioning the “CleanVent” CVA Microbubble Air separator in the system is important for optimum performance.

In heating systems this should be in the flow, preferably at the highest temperature (next to the heat source) and low pressure if possible.

The CVA should always be installed before equipment that needs protection (ie. controll valves, pumps, etc.)

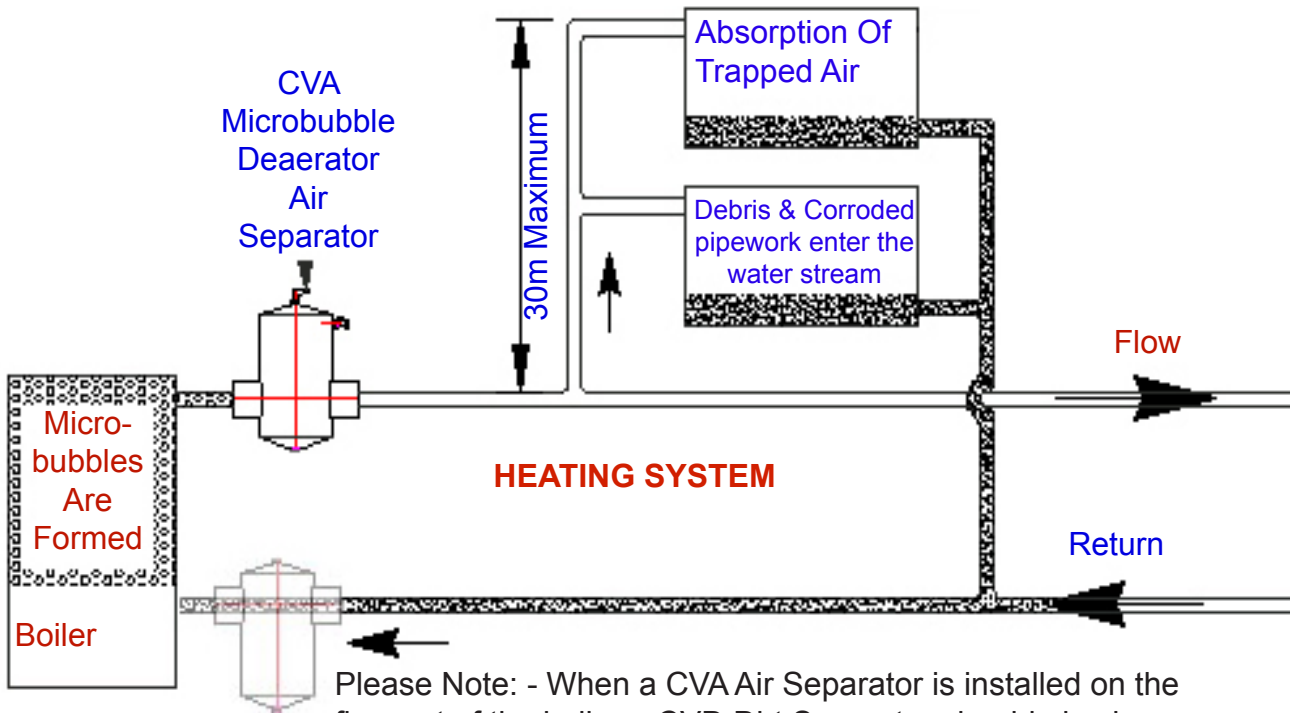

# Schematic instalation Schemes - "CleanVent" Range

This document describes where to install the "CleanVent" products in heating & cooling systems

## Specific rules

- 1) All models are in line units the water flows through them.
- 2) The positioning of the clean vent range to the pumps and control equipment is important !!
- 3) Consideration of all our range of units must be taken into account when specifying a unit applying to a specific contract.

- A) Is it a total new build.
- B) Is it a boiler house / plantroom refurbishment.
- C) Is there a particular problem with air or dirt (existing systems).
- D) Positioning of boiler house / plantroom regarding head of water.

## Air & Dirt or Air Only

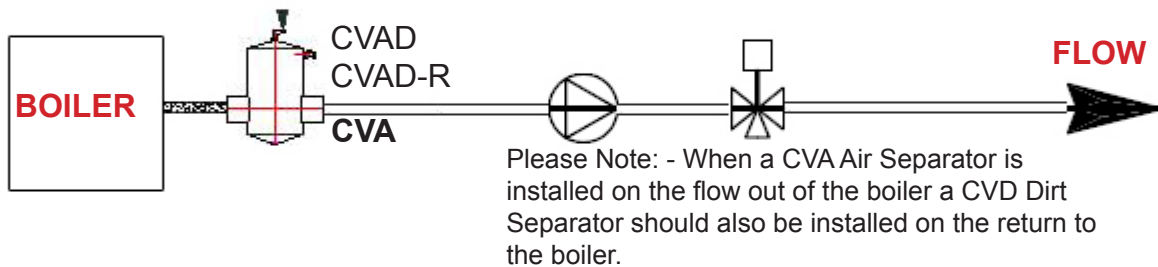

## Air & Dirt Only

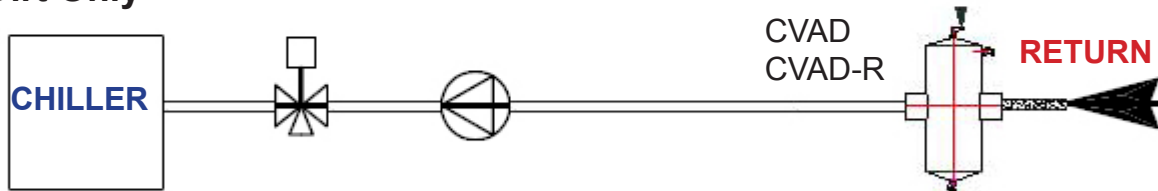

## Air & Dirt Only

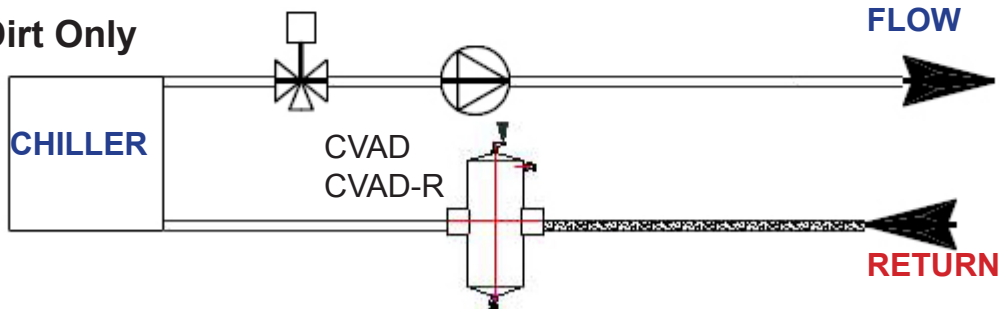

## Dirt Only

