



Fabricated Products (UK) Ltd

The Ickles, Unit 2, Sheffield Road, Rotherham, S60 1BN

Tel. 01709 720 842 - Fax. 01709 720 846

www.fabricatedproducts.co.uk Email: info@fabricatedproducts.co.uk

MICROBUBBLE AIR & DIRT SEPARATORS (Demountable) **The CleanVent (CVAD-R) Standard**

Standard Unit for flow rates up to 1.5m/s. For high flow see our CVAD-R-HF

An air, microbubble & dirt free water system through one unit

Deaeration

The word Deaeration describes the removal of dissolved gases from liquids such as air from water. When water is heated or the pressure reduced gas microbubbles are released into the system. Microbubbles can be the cause of major problems such as pump failure, corrosion and energy loss.

The Solution

The CleanVent combines the removal of air and dirt through a single unit. Installed at the hottest point in the system the CleanVent will eliminate these microbubbles from heating and chilled water systems.

Dirt Removal

The CleanVent is also used to remove dirt particles from heating and chilled water systems. Installed it will eliminate all dirt particles down to 5 microns.

Features

- * Greatly reduced commissioning times after initial fill.
- * Longer system life (through air and dirt elimination)
- * Low-pressure drop
- * Bi-directional flow
- * Maximum Temperature. 110 °c. Higher temperature units available on request.
- * Standard carbon steel shell (stainless on request)
- * Air collects in the air chamber before being automatically vented
- * Floating dirt can be removed by opening the valve situated on the side of the unit.
- * The same valve is used for releasing air when filling the system
- * Large collector ensures that flushing is only required now and then
- * Can be flushed while fully operational (no need to shut down)
- * An internal stainless steel concentrator to aid removal of air and dirt.
- * Maximum flow rate 1.5m/sec. Higher flow rates upto 3m/sec require our Hi-Flow unit CVAD-R-HF

CleanVent Location

This demountable combined unit (our model ref CVAD-R) must be installed at the hottest part of the system (before the pumps). In a heating system this is the main flow from the boilers. The static head must not exceed 30 metres.

In a chilled water system the unit must be located in the return close to the chiller. Maximum static head must not exceed 15 metres.

N.B. if the static head is greater than these figures the efficiency of the CleanVent is reduced.

Dirt separation only

This unit (our model ref CVD or CVD-R) should be installed in the return pipework before the flow of water enters any plant (boilers, pumps, etc.). There is no head restriction on this unit.

Air separation only

This unit (our model ref CVA) must be installed at the hottest part of the system (before the pumps). In a heating system this is the main flow from the boilers. The static head must not exceed 30 metres.

In a chilled water system the unit must be located in the return close to the chiller. Maximum static head must not exceed 15 metres.

The maximum flow rates through the CleanVent is 3m/sec. If these values are exceeded the efficiency is reduced.

Commissioning

The CleanVent requires no special commissioning. All units are fitted with a fast bleed valve, which should be used when initially filling the system. The same valve is used for draining off floating scum and also prevents the possibility of dirt clogging the air vent. Maintenance will be required to remove trapped dirt and sludge. Opening the ball valve at the bottom of the unit does this. The valve may be opened while the system is under pressure.

Scalding is a danger at high pressures and temperatures. Ensure that the water is safely piped to drain before opening the valve.

The system pressure will flush the dirt out. Leave the valve open until the collected dirt has been flushed out, repeat this operation every few days. Once the water is clear it may be possible to drain every 6 months or so depending on the size and age of the system.

Most of the dissolved air will be removed in a few days. However this may vary from system to system. In large systems it may take several weeks.

Dirt separators can only remove dirt that is circulating.

Flanges

All flanges are drilled to BS 4504 PN16 as standard. Plain ends and other flange rating are available on request.

The CleanVent unit is maintenance free.

Drain valve

All models are supplied with a ball valve for draining the collected dirt and sludge.





Fabricated Products (UK) Ltd

The Ickles, Unit 2, Sheffield Road, Rotherham, S60 1BN

Tel. 01709 720 842 - Fax. 01709 720 846

www.fabricatedproducts.co.uk Email: info@fabricatedproducts.co.uk

Combined unit Air (de-aerator)-& Dirt Separator Removable - Model CVAD-R

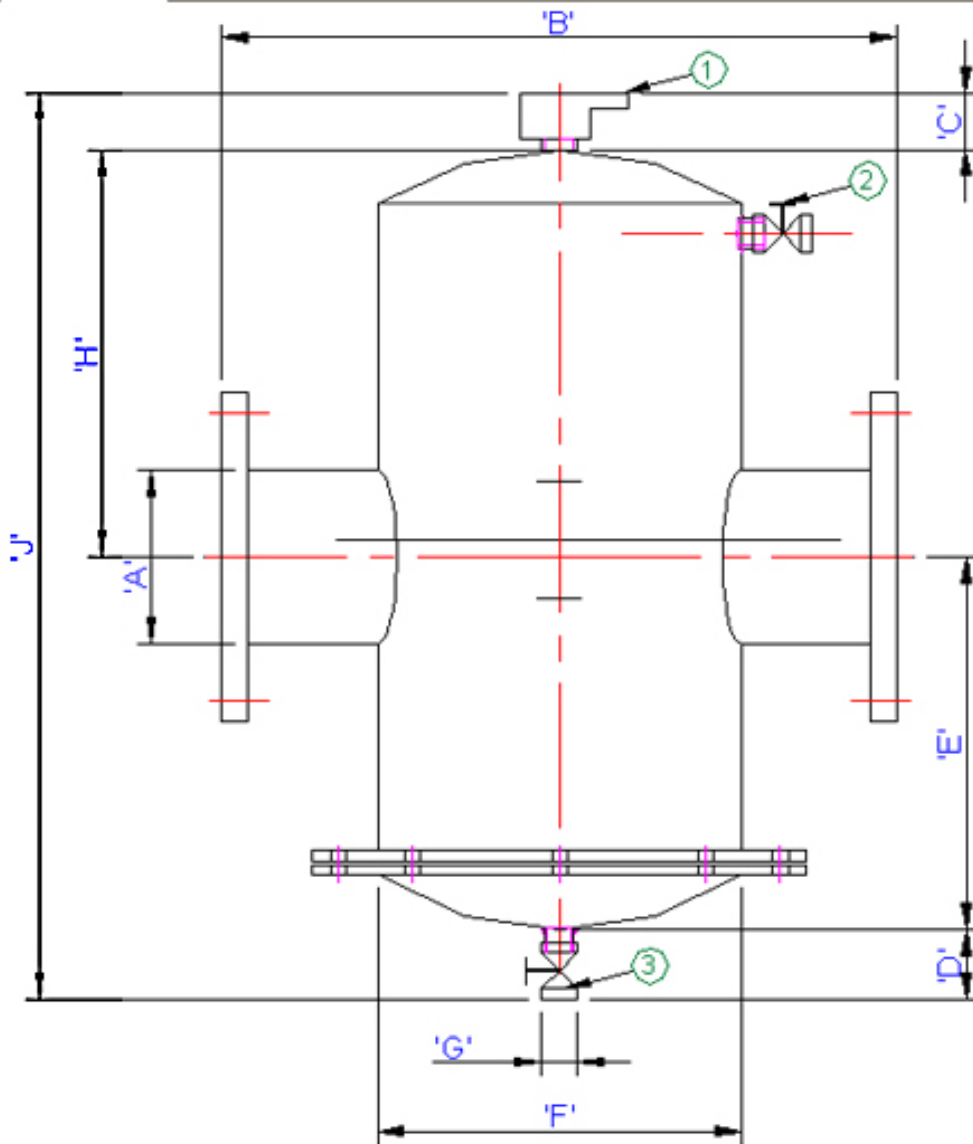

- (1) High Capacity Auto Air Vent
- (2) Fast Bleed Valve
- (3) Drain Valve

Product Code	DIMENSION'S									Test
	A	B	C	D	E	F	G	H	J	
CVAD-R50	50	350	130	120	250	170	25	170	670	21 Bar
CVAD-R65	65	350	130	120	250	170	25	170	670	21 Bar
CVAD-R80	80	460	130	120	310	220	25	280	840	21 Bar
CVAD-R100	100	460	130	120	310	220	25	280	840	21 Bar
CVAD-R125	125	630	130	120	410	325	25	380	1040	21 Bar
CVAD-R150	150	630	130	120	410	325	25	380	1040	21 Bar
CVAD-R200	200	810	130	200	490	410	50	410	1230	21 Bar
CVAD-R250	250	880	130	200	490	510	50	640	1460	21 Bar
CVAD-R300	300	1100	130	200	675	610	50	890	1895	21 Bar
CVAD-R350	350	1100	130	200	675	770	50	900	1905	21 Bar
CVAD-R400	400	1250	130	200	825	770	50	1000	2175	21 Bar
CVAD-R450	450	1250	130	200	825	920	50	1000	2175	21 Bar

Positioning the “CleanVent” CVAD-R Combined microbubble air & dirt separator in the system is important for optimum performance.

In heating systems this should be in the flow, preferably at the highest temperature (next to the heat source) and low pressure if possible.

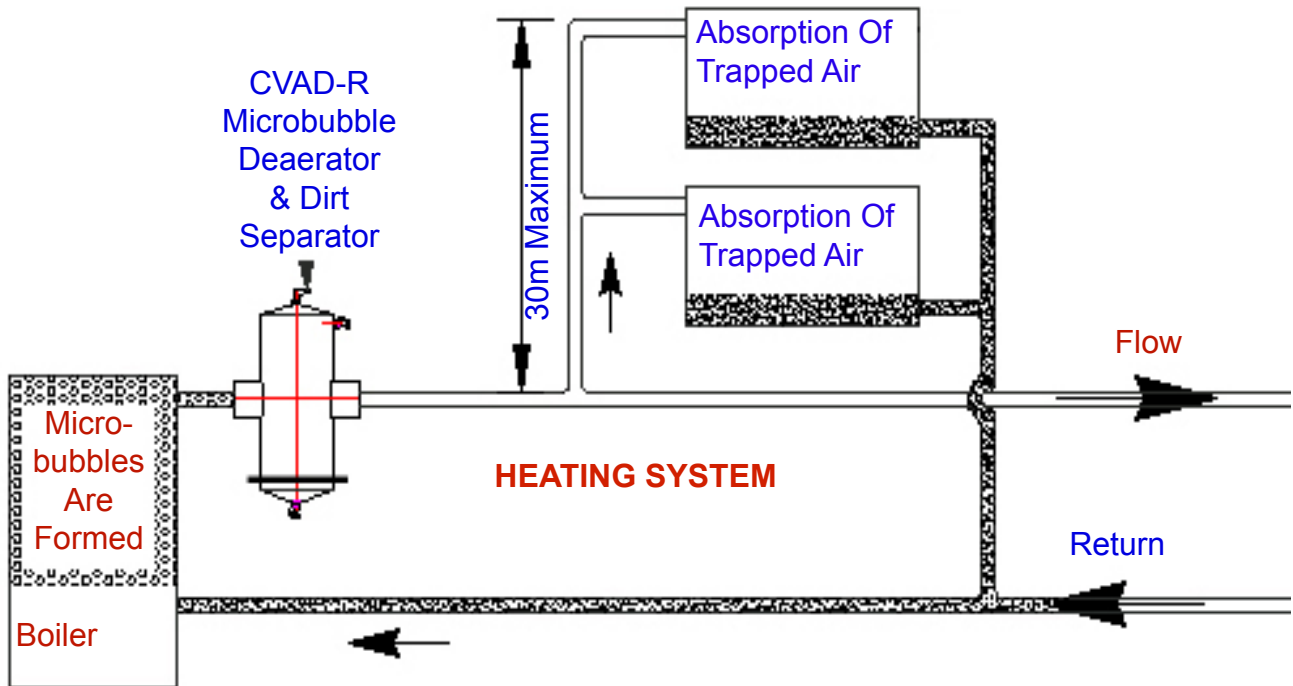

In cooling systems this should be in the return. The CVAD-R should always be installed before equipment that needs protection from dirt, sludge, etc., (ie. Chillers, control valves, pumps, etc.) In existing systems where there are problems with dirt, sludge, etc. a demountable unit should be installed, our CVAD-R will solve this problem. This applies to in and around the plantroom where new chiller unit and control equipment have been installed but the existing system has been left intact.

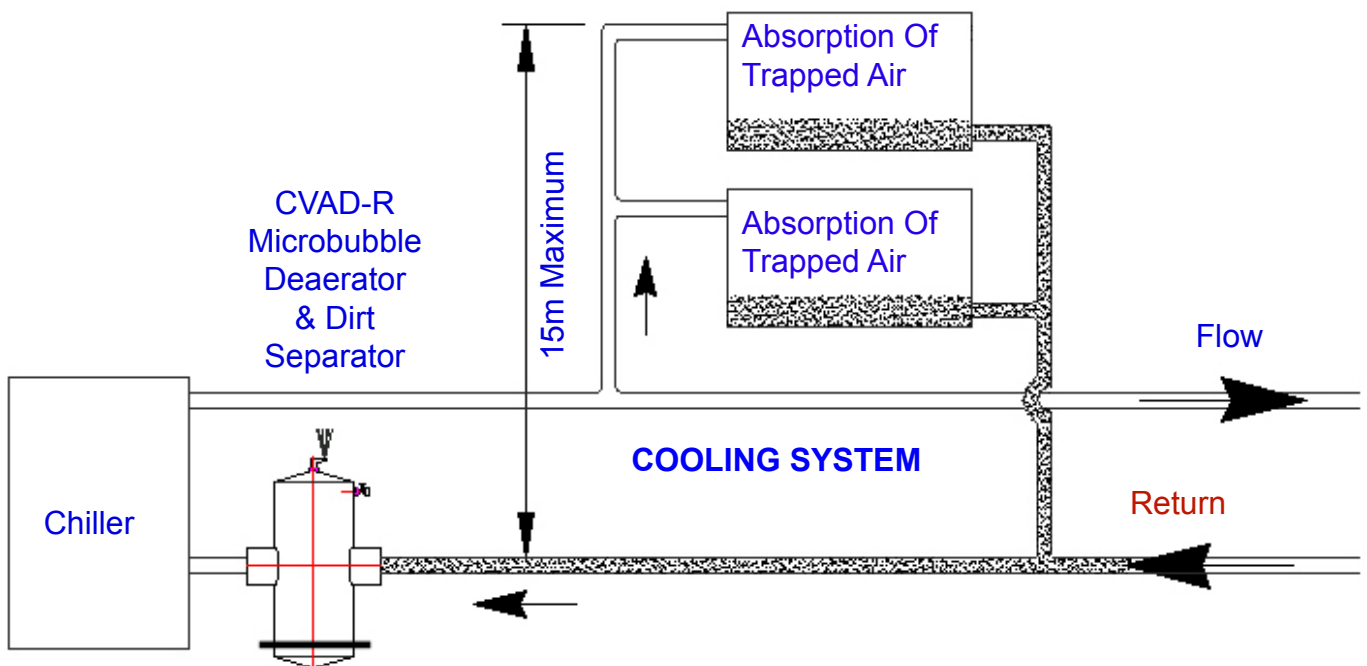

Schematic instalation Schemes - "CleanVent" Range

This document describes where to install the "CleanVent" products in heating & cooling systems

Specific rules

- 1) All models are in line units the water flows through them.
- 2) The positioning of the clean vent range to the pumps and control equipment is important !!
- 3) Consideration of all our range of units must be taken into account when specifying a unit applying to a specific contract.

- A) Is it a total new build.
- B) Is it a boiler house / plantroom refurbishment.
- C) Is there a particular problem with air or dirt (existing systems).
- D) Positioning of boiler house / plantroom regarding head of water.

Air & Dirt or Air Only

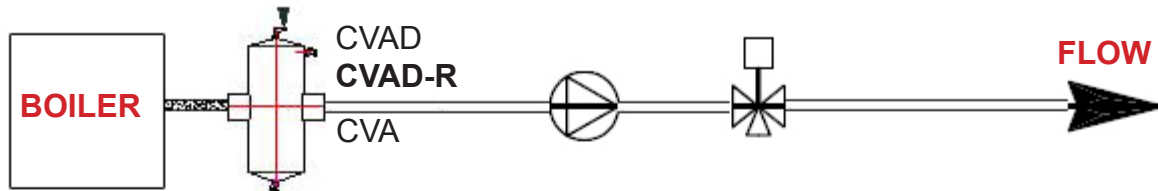

Air & Dirt Only

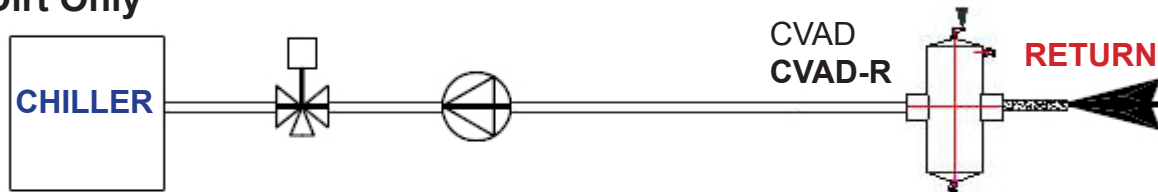

Air & Dirt Only

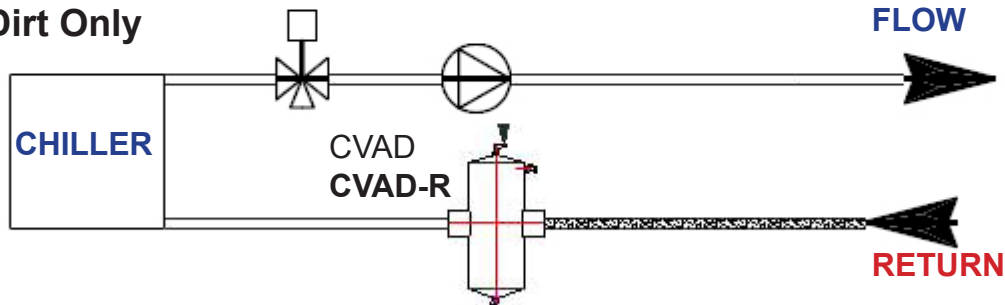

Dirt Only

